

HPL

7008 750W 115V 1CT



HPL lamps include a barrel-shaped filament that is approved by ETC for use in its Source Four™ fixtures. Bright, high quality light and high beam intensity is assured by the optimal filament design, while the unique P3 technology, developed by Philips, allows the lamp to be used at higher temperatures, which extends lifetime and consistency of high-quality light output, resulting in fewer early failures and fewer maintenance man hour costs.

Product data

• General Characteristics

Philips Code	7008
System Description	P3 Technology
Cap-Base	Heat Sink
Cap-Base Information	Heat Sink
Bulb Finish	Clear
Filament Shape	Bi-Plane
Operating Position	any
Main Application	Entertainment
Life to 50% failures	300 hr

• Light Technical Characteristics

Color Rendering Index	100 Ra8
Color Temperature Technical	3250 K
Luminous Flux Lamp	21900 Lm

• Electrical Characteristics

Watts	750 W
Voltage	115 V
Dimmable	Yes
Rapid Acting HBC	6.3 V
Fuse	

• Luminaire Design Requirements

Pinch Temperature	500 (max) C
-------------------	-------------

• Product Dimensions

Overall Length C	104 (max) mm
Diameter D	19 (max) mm
Light Center Length L	60.3 mm
Filament Dimensions (WxH) [mm]	6.3x10.5x6.3
Filament Height H	10.5 mm
Filament Length W	6.3 mm
Filament Depth D1	6.3 mm

• Product Data

Product number	391714
Full product name	7008 750W Heat Sink 115V 1CT
Short product name	7008 750W Heat Sink 115V 1CT/10
Pieces per Sku	1
eop_pck_cfg	10
Skus/Case	10
Bar code on pack	8711500185372
Bar code on case	8711500185488
Logistics code(s)	924555134428
eop_net_weight_pp	0.051 kg

Dimensional drawing

PHILIPS

sense and simplicity

Dimensional drawing

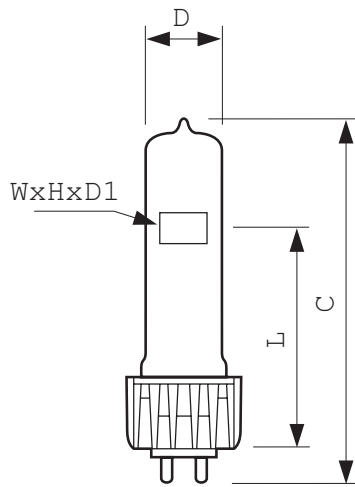

HPL

Product	C (Max)	D (Max)	D1 (Norm)	H (Norm)	L (Norm)	W (Norm)
7008 750W Heat Sink 115V	104	19	6.3	10.5	60.3	6.3



© 2012 Koninklijke Philips Electronics N.V.
All rights reserved.

Specifications are subject to change without notice. Trademarks are the property of Koninklijke Philips Electronics N.V. or their respective owners.

www.philips.com/lighting

2012, April 16
data subject to change